



# Model No. SV-Series Valve BUTTERFLY GAS VALVE AND ACTUATOR

Support 877-351-4702



	<p>Conforms to CSA/ANSI STD Z21.21 Certified to CSA STD 6.5</p>
<p><b>Intertek</b></p>	
<p>4007066</p>	

### This manual covers the following products:

SV-Series Valve Butterfly gas valve with 15 second actuator

### Table of Contents

Overview.....	2
Installation and Startup.....	2
Assembly and Wiring.....	2
Setting Minimum Position.....	3
Diagnostics.....	3
Pressure Drop Chart.....	4
Specifications.....	5

## Overview

The RTC SV- Series Valve is a butterfly gas valve. The SV-Series uses a 15 second actuator, powered by 24VAC or DC and is driven by an analog 2-10VDC signal. It is designed for low pressure applications (<5 PSI) for the control of Natural Gas and/or Propane downstream of any pressure regulators and/or shut-off valves. It is comprised of two components: A metal valve and a separate and self-contained actuator. The valve is NOT designed as a shut-off valve or a safety valve. It is designed so that some flow still exists even when the valve is in the “closed” position.

## Installation and Startup

Install the valve body by threading both sides into the gas train. The SV-Valve is bi-directional, so it can be installed in any direction or orientation. Use proper thread sealer to prevent leakage.

Attach the actuator by aligning the brass stem on the valve body with the actuator socket. Then align the actuator guide pins to the valve bonnet openings and press down until a click is heard. To remove the actuator, grasp it with your hand and pull it straight up from the valve body(See Fig. A). Refer to Fig. B for wiring instructions.

Once power is applied to the actuator for the first time, it will execute the adaption routine. During the adaption routine the actuator will scale the control signal across the available travel(Between the “Fully Open” position and the Minimum Setting Clip). The adaption routine does not change the actuator speed, which is 15 seconds over 90 degree rotation.

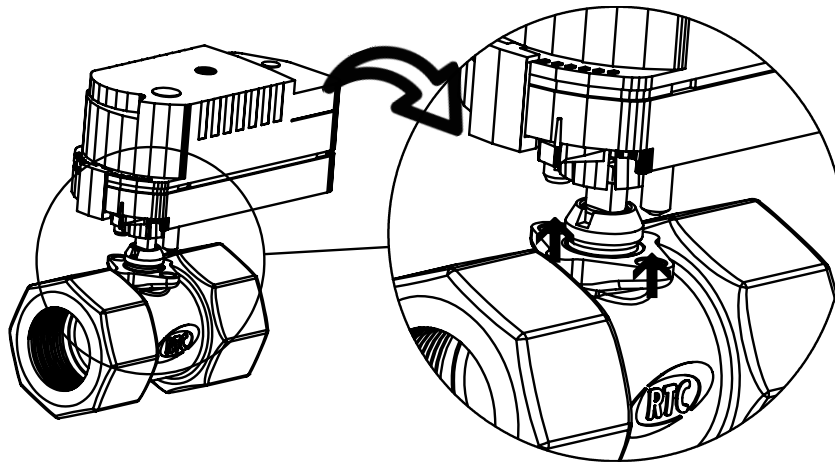
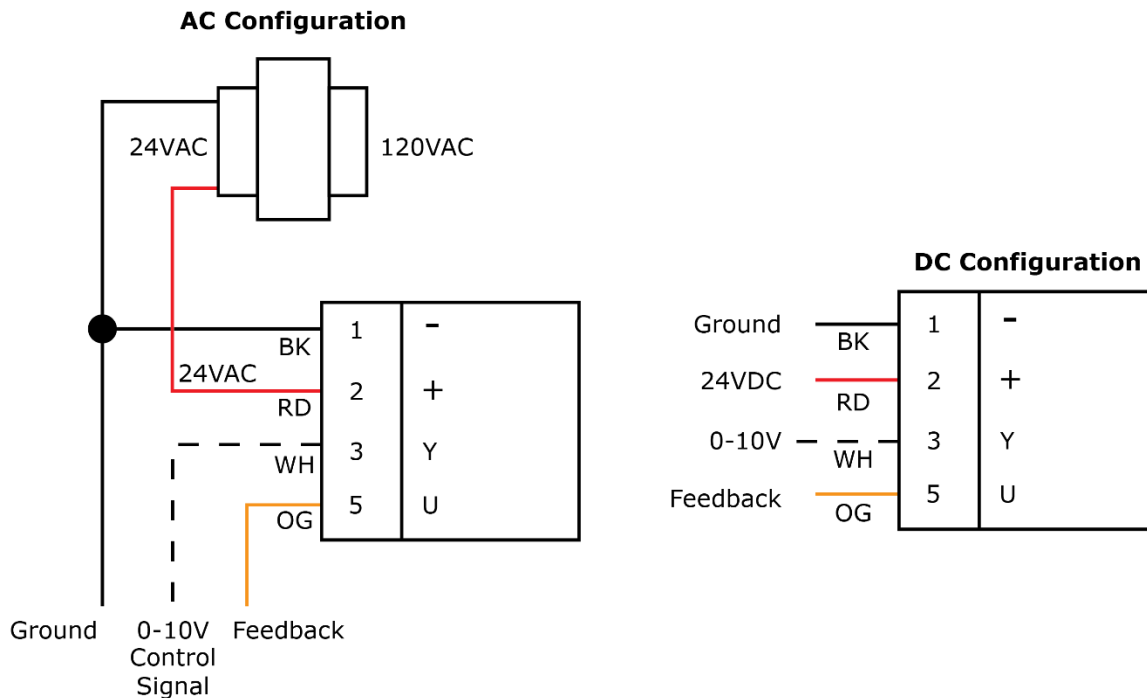

Figure A



## Setting Minimum Position

After startup, if you desire a different Minimum Setting Position, execute the following steps:

**Before pressing the adaption button be prepared to remove power to the actuator.**

1. Once power is applied to the actuator, press the adaption button – This will first send the valve/indicator to the “Zero” position and then toward the “Fully Open” position. When the valve/indicator stalls at the “Fully Open” position, remove power from the actuator. – This will stop the valve/indicator in its current position.
2. Remove the minimum setting clip by popping it off with a flathead screw driver (See Fig. C).
3. Once the minimum setting clip is removed, move it one notch toward the open position (See Fig. D).
4. Reapply power to the actuator. – The indicator will first move to the “Zero” position, stall, and then to the “Fully Open” position, stall, and lastly to the commanded position of the control signal. If no control signal is connected the indicator will move to absolute zero.
5. Once the Minimum Setting Position is adjusted, press the adaption button again to obtain the new scale for the control signal.

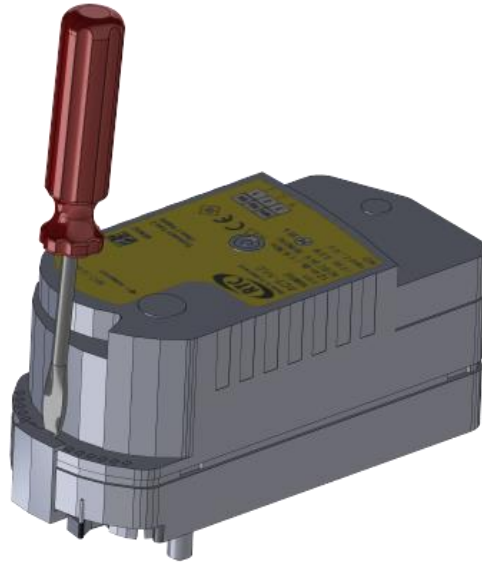

Figure C

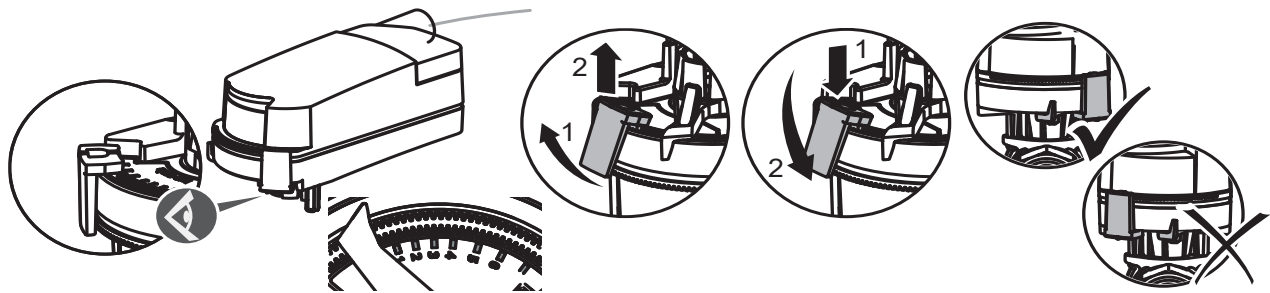

Figure D

## Diagnostics

1. Valve is stuck open, closed or not responding:
  - a. Press the adaption button. This will open and close the valve to both it's minimum and maximum. This will tell you if the actuator is receiving power and if the actuator is working mechanically.
  - b. Next, check the signal using a signal generator or a 9V battery. You want to make sure that the signal is affecting the position of the valve. At 2V the valve should be at it's minimum position and at 10V the valve should be at it's maximum position. Verifying the temperature change will tell you if the actuator is turning the butterfly valve.

## SV-Series Valve Pressure Drop Chart

Model Number	SV-1.2NN	SV-3.4NN	SV-1.0NN	SV-11.4NN	SV-11.2NN	SV-2.0NN
Flow Rate(CFH)	Pressure Drop (inches w.c.)					
100	0.07	0.07	0	0		
150	0.16	0.16	0.01	0.01		
200	0.29	0.29	0.01	0.01		
250	0.45	0.45	0.02	0.02		
300	0.65	0.65	0.03	0.03		
350	0.88	0.88	0.03	0.03		
400	1.16	1.16	0.04	0.04		
450	1.46	1.46	0.06	0.06		
500	1.81	1.81	0.07	0.07		
550	2.18	2.18	0.08	0.08		
600	2.6	2.6	0.1	0.1		
650	3.05	3.05	0.12	0.12		
700	3.54	3.54	0.14	0.14		
750	4.06	4.06	0.16	0.16		
800	4.62	4.62	0.18	0.18		
850	5.22	5.22	0.2	0.2		
900	5.85	5.85	0.23	0.23	0.01	0.01
950	6.52	6.52	0.25	0.25	0.02	0.02
1000			0.28	0.28	0.02	0.02
1100			0.34	0.34	0.02	0.02
1200			0.4	0.4	0.03	0.03
1500			0.63	0.63	0.04	0.04
2000			1.12	1.12	0.07	0.07
2500			1.75	1.75	0.11	0.11
3000			2.52	2.52	0.16	0.16
3500					0.21	0.21
4000					0.28	0.28
5000					0.44	0.44
6000					0.63	0.63
7000					0.86	0.86
8000					1.12	1.12
9000					1.42	1.42
10000					1.75	1.75

## Specifications Actuator

Power Requirements	24VAC , ± 20%, 50/60 Hz, 24VDC, ± 10%
Power Consumption Running	0.5 W
Transformer Sizing	0.1VA (class 2 power source)
Electrical Connection	Screw Terminal (for 26 to 14 GA wire)
Overload Protection	Electronic throughout 0° to 90° rotation
Operating Range Y	2 to 10 VDC, 4 to 20 mA w/ ZG-R01 (500Ω, ¼ W resistor)
Angle of Rotation	90°, adjustable with mechanical stop
Position Indication	Pointer
Running Time (Motor)	15 sec
Ambient Humidity	5 to 95% RH non condensing (EN 60730-1)
Ambient Temp Range	-40°F to 140°F (-40°C to 60°C)
Storage Temp Range	-40°F to 176°F (-40°C to 80°C)
Housing	IP40, NEMA 2
Housing Material	UL94-5VA
Agency Listings	cULus acc. To UL60730-1A/-2-14, Can/CSA E60730-1:02, CE acc. To 2004/108/EC and 2006/95/EC
Noise Level (Motor)	max. 35 dB (A)
Servicing	Maintenance Free
Quality Standard	ISO 9001
Weight	0.2lb (0.1kg)
Degree of protection IEC/EN	IP40

## Valve

Pressure Rating	5PSI
Agency Listing	ETL
	ANSI STD Z21.21
	CSA STD 6.5
Ambient Temp Range	-40°F to 140°F (-40°C to 60°C)